

General Description

SDC4565 is a highly integrated current mode PWM control IC optimized for high performance, low standby power and cost effective offline flyback converter applications in sub 60W range.

The internal slope compensation improves system large signal stability and reduces the possible subharmonic oscillation at high PWM duty cycle output. Leading-edge blanking on current sense (CS) input removes the signal glitch due to snubber circuit diode reverse recovery and thus greatly reduces the external component count and system cost in the design.

SDC4565 offers complete protection coverage with automatic self-recovery feature including cycle-by-cycle current limiting (OCP), over load protection (OLP), VDD over voltage clamp and under voltage lockout (UVLO). The gate drive output is clamped to maximum 12V to protect the power MOSFET.

Features

- Frequency shuffling technology for improved EMC performance
- Audio noise free operation
- Extended burst mode control for improved efficiency and minimum standby power design
- External programmable PWM switching
- Internal synchronized slope compensation
- Low VDD startup current and low operating current
- Leading edge blanking on current sense input
- Good protection coverage with auto self-recovery (UVLO/OVP/OCP/OLP)
- Package: SOT-23-6

Applications

- Battery charger
- Power adapter
- Set-top box power supplies



Figure 1. Package Type

Pin Configuration

Figure 2. Pin Configuration

Pin Number	Pin Name	Function
1	GND	Ground
2	FB	Feedback input pin. The PWM duty cycle is determined by voltage level into this pin and SENSE pin input
3	RI	Internal Oscillator frequency setting pin. A resistor connected between RI and GND set the PWM frequency
4	SENSE	Current sense input pin. Connected to MOSFET current sensing resistor node
5	VDD	Chip DC power supply pin
6	GATE	Totem-pole gate drive output for the power MOSFET

Table 1. Pin Description

Functional Block Diagram

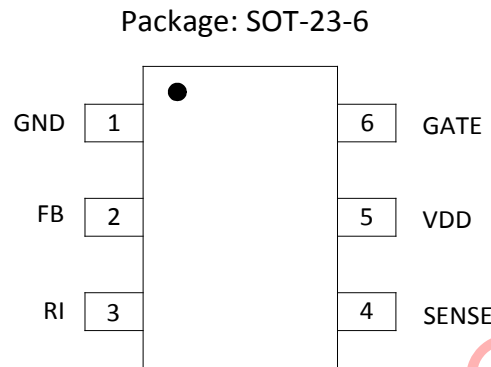
Figure 3. Functional Block Diagram

Ordering Information

Package	Temperature Range	Part Number		Marking ID		Packing Type
		Pb-free	Halogen-free	Pb-free	Halogen-free	
SOT-23-6	-40°C~85°C	SDC4565JTR-E1	SDC4565JTR-G1	4565	4565G	Tape Reel

Absolute Maximum Ratings (NOTE: Stresses greater than those listed under Absolute Maximum Ratings may cause permanent damage to the device.)

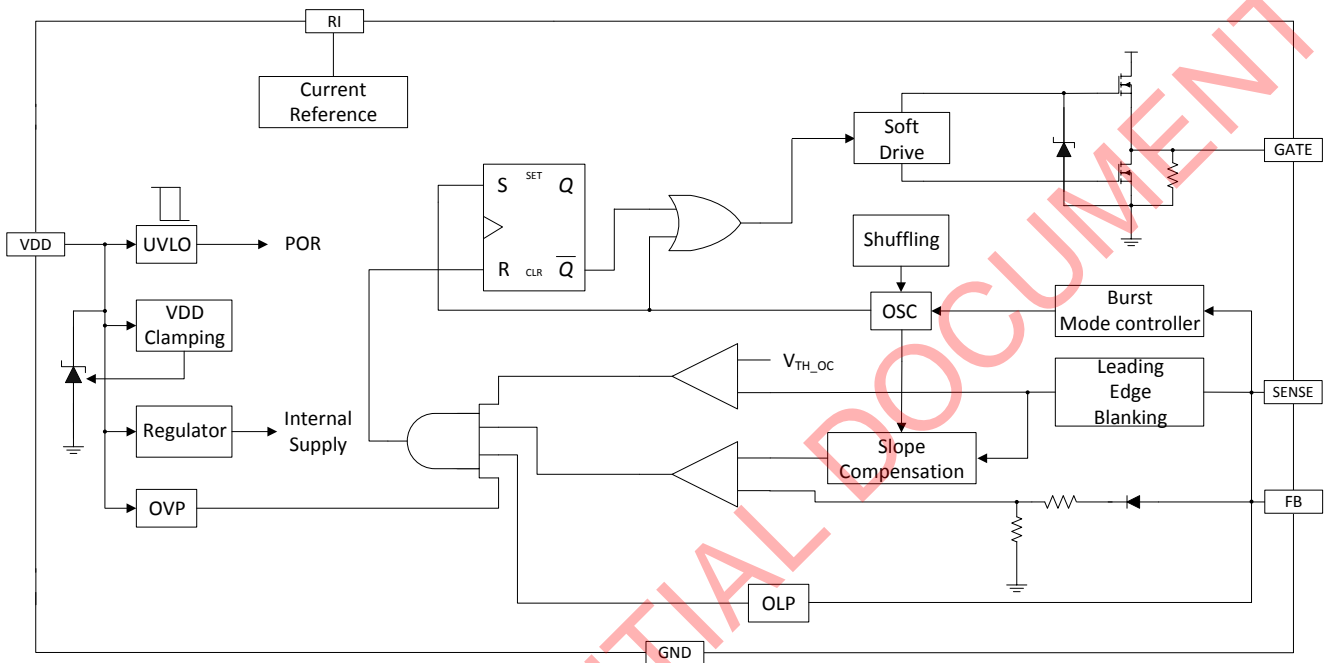
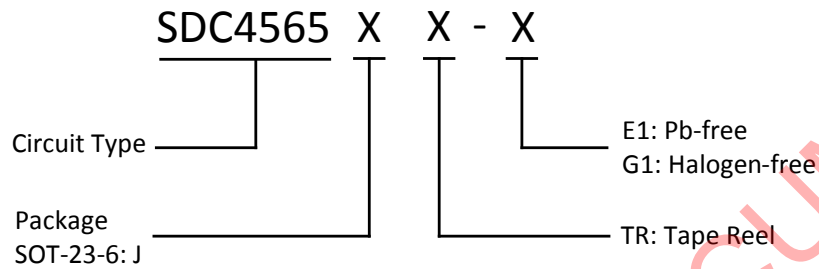
Parameter	Symbol	Value	Unit
VDD DC supply voltage	V_{DD}	-0.3~30	V
VDD clamp voltage	V_{DD_CLAMP}	32	V
VDD DC clamp current	I_{CLAMP}	10	mA
V_{FB} input voltage	V_{FB}	-0.3~7	V
SENSE input voltage	V_{SENSE}	-0.3~7	V
V_{RI} input voltage	V_{RI}	-0.3~7	V
Operating junction temperature T_J	T_J	150	°C
Storage temperature T_{STG}	T_{STG}	-55~150	°C
Latch-up test per JEDEC 78	-	200	mA
ESD,HBM model per Mil-Std-883H,Method 3015	HBM	2000	V
ESD,MM model per JEDEC EIA/JESD22-A115	MM	200	V

Table 2. Absolute Maximum Ratings

Recommended Operating Conditions

Parameter	Symbol	Min	Max	Unit
VDD DC supply voltage	V_{DD}	10	30	V
Oscillation frequency	f_{OSC}	60	70	kHz
Operating Temperature Range	T_{OP}	-40	85	°C

Table 3. Recommended Operating Conditions

Electrical Characteristics (Ta=25°C, unless otherwise specified)

Parameter	Symbol	Condition	Min	Typ	Max	Unit
Supply Voltage (VDD)						
VDD start up current	I _{STARTUP}	V _{DD} =12.5V, RI=100k, Measure Leakage current into VDD	-	3	20	uA
Operation current	I _{DD}	V _{DD} =16V, RI=100k, V _{FB} =3V	-	1.4	-	mA
VDD under voltage lockout enter	V _{UVLO(ON)}	-	7.2	8.2	9.2	V
VDD under voltage lockout exit (recovery)	V _{UVLO(OFF)}	-	13.5	14.5	15.5	V
VDD zener clamp voltage	V _{DD_CLAMP}	I _{VDD} =10mA	30	32	34	V
Feedback Input Section(FB Pin)						
FB open loop voltage	V _{FB_OPEN}	-	-	4.8	-	V
FB pin short circuit current	I _{FB_SHORT}	Short FB pin to GND and Measure Current	-	0.8	-	mA
Zero duty cycle fb threshold voltage zero	V _{TH_OD}	V _{DD} =16V, RI=100k	-	-	0.85	V
Power limiting FB threshold voltage	V _{TH_PL}	-	-	3.7	-	V
Power limiting debounce time	t _{D_PL}	-	-	35	-	ms
Maximum duty cycle	DC _{MAX}	V _{DD} =16V, RI=100k, FB=3V, CS=0	70	80	90	%
Current Sense Input(Sense Pin)						
Leading edge blanking time	t _{BLANKING}	RI=100k	-	300	-	ns
Over current detection and control delay	t _{D_OC}	V _{DD} =16V, CS>V _{TH_OC} , FB=3.3V	-	75	-	ns
Over current threshold voltage at zero duty cycle	V _{TH_OC}	FB=3.3V, RI=100k	0.70	0.75	0.81	V
Oscillator						
Normal oscillation frequency	f _{OSC}	RI=100k	60	65	70	kHz
Frequency temperature stability	Δf _{TEMP}	V _{DD} =16V,RI=100k, Ta=-20°C~100°C	-	5	-	%
Frequency voltage stability	Δf _{VDD}	V _{DD} = 12V~25V,RI=100k	-	5	-	%

Parameter	Symbol	Condition	Min	Typ	Max	Unit
RI open load voltage	V_{RI_OPEN}	-	-	2	-	V
Burst mode base frequency	f_{BM}	$V_{DD}=16V, RI=100k$	-	22	-	kHz
Soft start time	t_{SOFT}	-	-	7	-	ms
Gate Drive Output						
Output low level	V_{OL}	$V_{DD}=16V, I_o=-20mA$	-	-	0.8	V
Output high level	V_{OH}	$V_{DD}=16V, I_o=20mA$	10	-	-	V
Output clamp voltage level	V_{CLAMP}	-	-	12	-	V
Output rising time	t_r	$V_{DD}=16V, CL=1nf$	-	125	-	ns
Output falling time	t_f	$V_{DD}=16V, CL=1nf$	-	50	-	ns
Frequency Shuffling						
Shuffling frequency	f_{OSC}	$RI=100k$	-	64	-	Hz
Modulation range/Base frequency	Δf_{OSC}	$RI=100k$	-3	-	3	%

Table 4. Electrical Characteristics

Function Description

The SDC4565 is a highly integrated PWM controller IC optimized for offline flyback converter applications in sub 60W power range. The extended burst mode control greatly reduces the standby power consumption and helps the design easily meet the international power conservation requirements.

Startup Current and Start up Control

Startup current of SDC4565 is designed to be very low so that VDD could be charged up above UVLO threshold level and device starts up quickly. A large value startup resistor can therefore be used to minimize the power loss yet provides reliable startup in application.

Operating Current

The operating current of SDC4565 is low at 1.4mA. Good efficiency is achieved with SDC4565 low operating current together with extended burst mode control features.

Frequency shuffling for EMI improvement

The frequency shuffling/jittering (switching frequency modulation) is implemented in SDC4565. The oscillation frequency is modulated with a random source so that the tone energy is spread out. The spread spectrum minimizes the conduction band EMI and therefore reduces system design challenge.

Extended Burst Mode Operation

Under zero load or light load condition, meet of the power dissipation in a switching mode power supply is from switching loss on the MOSFET transistor, the core loss of the transformer and the loss on the snubber circuit. The magnitude of power loss is in proportion to the number of switching events within a fixed period of time, Reducing switching frequency leads to the reduction on power loss and thus conserves the energy.

SDC4565 self adjusts the switching mode according to the loading condition. Under no load to light/medium load

condition, the FB input drops below burst mode threshold level, device enters burst mode control. The gate drive output switches only when VDD voltage drops below a preset level and FB input is active to output an on state, otherwise the gate drive remains at off state to minimize the switching loss and reduces the standby power consumption to the greatest extend. The frequency control also eliminates the audio noise at any loading conditions.

Oscillator Operation

A resistor connected between RI and GND sets the constant current source to charge/discharge the internal cap and thus the PWM oscillator frequency is determined. The relationship between RI and switching frequency follows the below equation within the specified RI in k Ω range at nominal loading operational condition.

$$f_{osc} = \frac{6500}{RI(k\Omega)} (kHz)$$

Current Sensing and Leading Edge Blanking

Cycle-by-cycle current limiting is offered in SDC4565 current mode PWM control. The switch current is detected by a sense resistor into the sense pin. An internal leading edge blanking circuit chops off the sense voltage spike at initial MOSFET on state due to snubber diode reverse recovery so that the external RC filtering on sense input is no longer required. The current limit comparator is disabled and thus cannot turn off the external MOSFET during the blanking period. PWM duty cycle is determined by the current sense input voltage and the FB input voltage.

Internal Synchronized Slope Compensation

Built-in slope compensation circuit adds voltage ramp onto the current sense input voltage for PWM generation. This greatly improves the close loop stability at CCM and

prevents the sub-harmonic oscillation and thus reduces the output ripple voltage.

Gate Drive

SDC4565 gate is connected to an external MOSFET gate for power switch control. Too weak the gate drive strength results in higher conduction and switch loss of MOSFET while too strong gate drive output compromises the EMI. A good tradeoff is achieved through the built-in totem pole gate design with right output strength and dead time control. The low idle loss and good EMI system design is

easier to achieve with this dedicated control scheme. An internal 12V clamp is added for MOSFET gate protection at higher than expected VDD input.

Protection Controls

Good power supply system reliability is achieved with its rich protection features including cycle-by-cycle current limiting (OCP), over load protection (OLP) and over voltage clamp, under voltage lockout on VDD (UVLO).

Typical Application

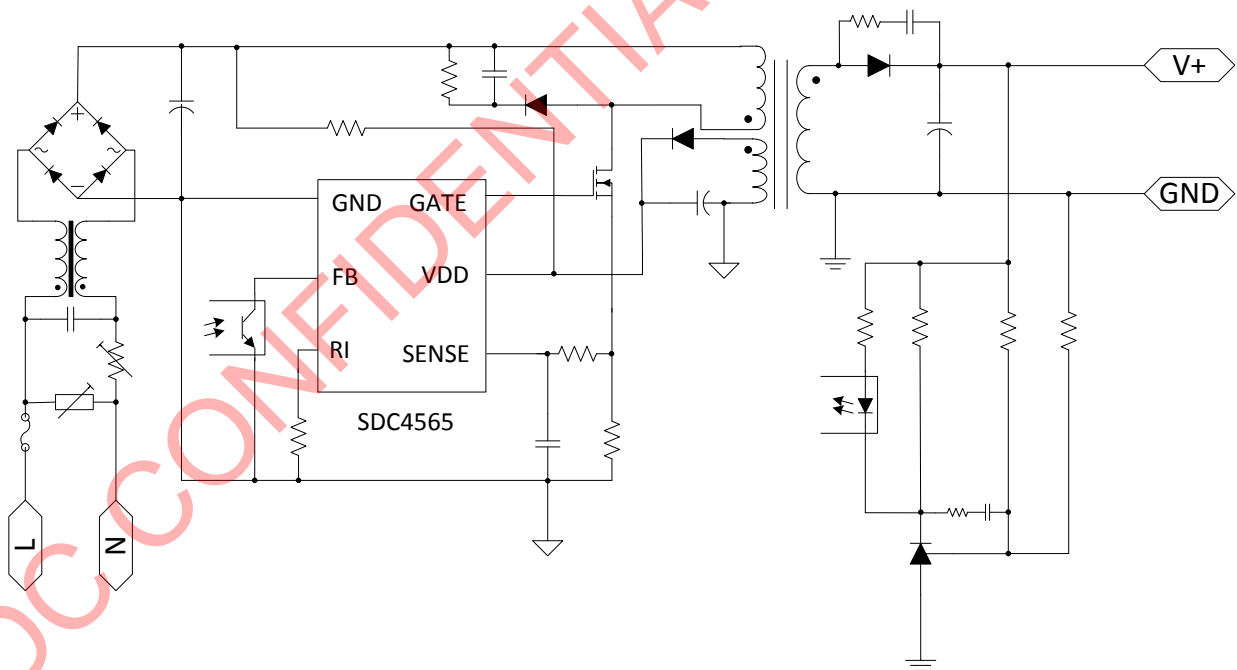
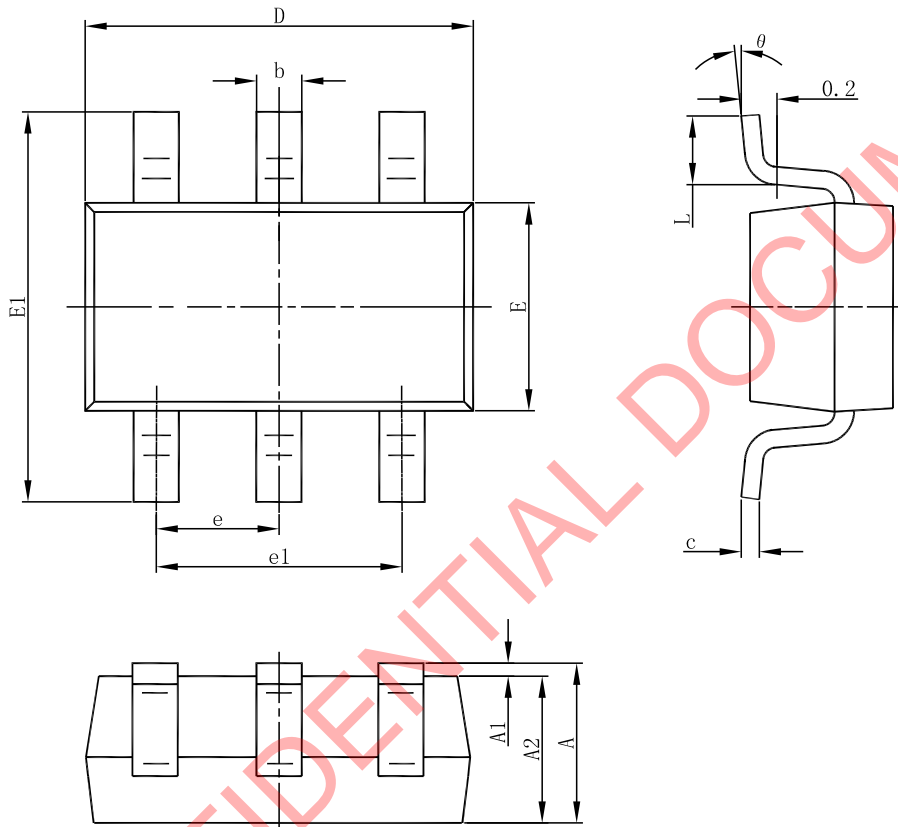

Figure 4. Typical Application

Package Dimension
SOT-23-6

Symbol	Dimensions In Millimeters		Dimensions In Inches	
	Min	Max	Min	Max
A	1.050	1.250	0.041	0.049
A1	0.000	0.100	0.000	0.004
A2	1.050	1.150	0.041	0.045
b	0.300	0.500	0.012	0.020
c	0.100	0.200	0.004	0.008
D	2.820	3.020	0.111	0.119
E	1.500	1.700	0.059	0.067
E1	2.650	2.950	0.104	0.116
e	0.950(BSC)		0.037(BSC)	
e1	1.800	2.000	0.071	0.079
L	0.300	0.600	0.012	0.024
θ	0°	8°	0°	8°



Shaoxing Devechip Microelectronics Co., Ltd.

<http://www.sdc-semi.com/>

IMPORTANT NOTICE

Information in this document is provided solely in connection with Shaoxing Devechip Microelectronics Co., Ltd. (abbr. SDC) products. SDC reserves the right to make changes, corrections, modifications or improvements, to this document, and the products and services described herein at anytime, without notice. SDC does not assume any responsibility for use of any its products for any particular purpose, nor does SDC assume any liability arising out of the application or use of any its products or circuits. SDC does not convey any license under its patent rights or other rights nor the rights of others.

© 2013 Devechip Microelectronics - All rights reserved

Contact us:

Headquarters of Shaoxing

Address: Tian Mu Road, No13,

Shaoxing city, Zhejiang province, China

Zip code: 312000

Tel: (86) 0575-8861 6750

Fax: (86) 0575-8862 2882

Shenzhen Branch

Address: 22A, Shangbu building, Nan Yuan Road, No.68,

Futian District, Shenzhen city, Guangdong province, China

Zip code: 518031

Tel: (86) 0755-8366 1155

Fax: (86) 0755-8301 8528