

General Description

The SDC11558 is a single phase full wave motor driver for DC fan motors, and can apply to three type speed control methods. The output signals of this IC are the amplifications of hall input signals. It is suitable for both game machine and CPU cooler that need silent fans. The device is built-in lock protection. When the fan is locked, the device will enter the lockup protection mode. It is also with thermal shutdown function. In normal operation, the supply current is less than 5mA. The SDC11558 is available in MSOP-10 package.

Features

- Silent driver
- Three speed control methods
- Built-in lock protection and auto restart function
- Low standby current (PWM=0), supply current less than 200uA (Type C only)
- Adjustable fan speed slope (Type B only)
- FG output
- Include hall bias circuit
- Built-in thermal protection circuit(RoHS compliant)
- Low duty start up

Applications

- Motor drivers for silent fan motors

Pin Configuration

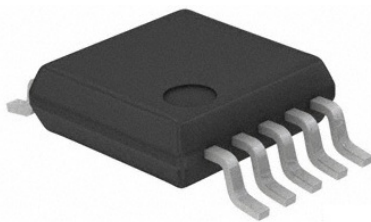

MSOP-10

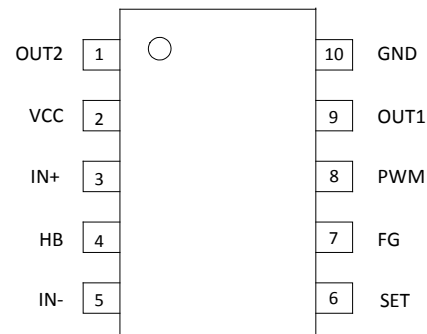

Figure 1. Pin Configuration

Pin Number	Pin Name	Function
1	OUT2	Motor output terminal 2
2	VCC	Power supply terminal
3	IN+	Hall input terminal+
4	HB	Hall bias terminal
5	IN-	Hall input terminal-
6	SET	Speed slope setting terminal.
7	FG	FG signal output terminal
8	PWM	PWM signal input terminal
9	OUT1	Motor output terminal 1
10	GND	GND terminal

Table 1. Pin Description

Functional Block Diagram

Figure 2. Functional Block Diagram

Ordering Information

Package	Temperature Range	Part Number		Marking ID		Packing Type
		Pb-free	Halogen-free	Pb-free	Halogen-free	
MSOP-10	-40°C~85°C	SDC11558MTR-E1	SDC11558MTR-G1	11558	11558G	Tape
		SDC11558M-E1	SDC11558M-G1	11558	11558G	Tube

Absolute Maximum Ratings (Note: Stresses greater than those listed under Absolute Maximum Ratings may cause permanent damage to the device.)

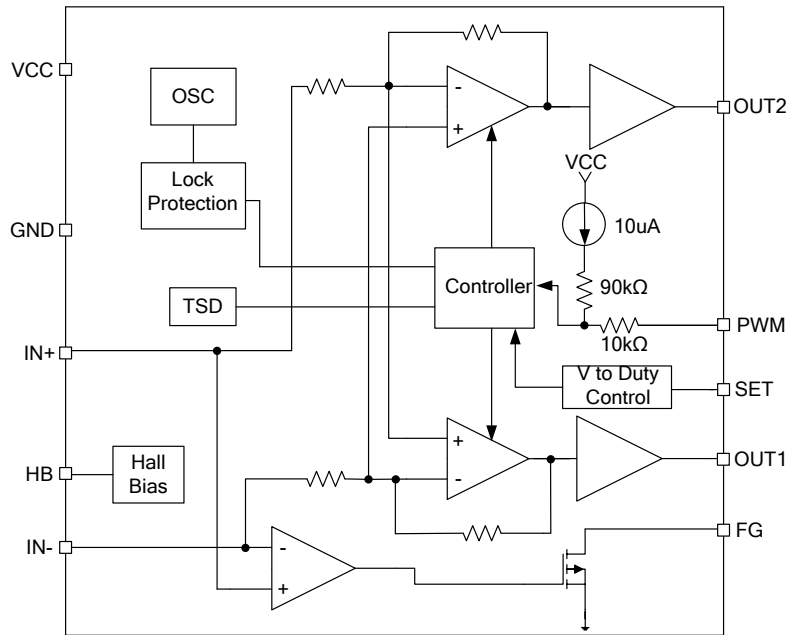
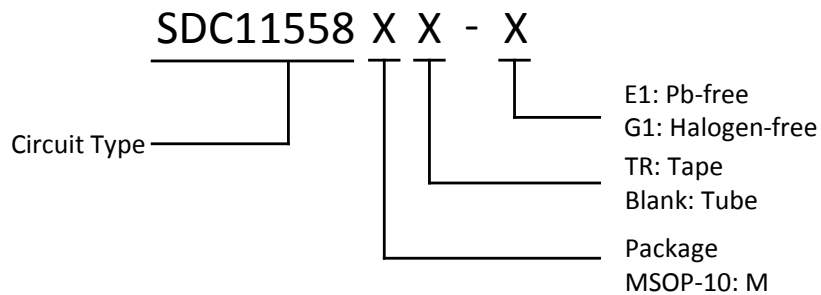
Parameter	Symbol	Conditions	Min	Max	Unit
VCC pin supply voltage	V_{CC}	-	-0.3	8.0	V
Output pin maximum output current	I_{OUT}	-	-	1.0	A
Output pin output voltage	V_{OUT}	-	-0.3	8.0	V
HB pin maximum output current	I_{HB}	-	-	10.0	mA
FG pin output voltage	V_{FG}	-	-0.3	8.0	V
FG pin maximum output sink current	I_{FG}	-	-	10.0	mA
VH/VL pin supply voltage	V_{SET}	-	-0.3	8.0	V
Storage temperature range	T_{STG}	-	-65	150	°C
Maximum lead soldering temperature, 10 seconds	T_{SDR}	-	-	260	°C
Maximum junction temperature range	T_J	-	-40	150	°C

Table 2. Absolute Maximum Ratings

Recommended Operating Conditions

Parameter	Symbol	Conditions	Min	Max	Unit
VCC pin supply voltage range	V_{CC}	-	2.0	6.0	V
Hall input voltage range	V_{HALL}	-	0.4	$V_{CC}-1.1$	V
SET pin input voltage range	V_{SET}	-	0.1	V_{HB}	V
Ambient temperature	T_a	-	-40	105	°C

Table 3. Recommended Operating Conditions

Electrical Characteristics ($T_a=25^{\circ}C$, $V_{CC}=5V$, unless otherwise specified)

Parameter	Symbol	Conditions	Min	Typ	Max	Unit
HB pin output voltage	V_{HB}	$I_{HB}=-5mA$	1.1	1.3	1.5	V
Operating current	I_{CC1}	Rotation mode and lock protection mode	-	4	5	mA
	I_{CC2}	Standby mode (PWM=0)	-	0.1	0.2	μA
Lock detection on time	t_{ON}	-	0.35	0.5	0.65	S
Lock detection off time	t_{OFF}	-	3.5	5	6.5	S
Output driver saturation voltage	V_O	$I_{OUT} = 250mA$, Upper and lower total	-	0.3	0.44	V
FG pin low voltage	V_{FG}	$I_{FG} = 5mA$	-	0.2	0.4	V
FG pin leakage current	I_{FGL}	$V_{FG} = 5V$	-	<0.1	1	μA
Input - output gain	GIO	$V_{OUT}/(V_{IN+} \sim V_{IN-})$	44	45	46	dB
SET pin high level input leakage	I_{SETH}	$V_{SET} = V_{CC}$	-	-	0.1	μA
SET pin low level output current	I_{SETL}	$V_{SET} = 0V$	-	1	-	μA
PWM input high level voltage	V_{PWMH}	-	$0.5 \times V_{CC}$	-	$V_{CC}+0.5$	V

Electrical Characteristics (Ta=25°C, V_{CC}=5V, unless otherwise specified)

Parameter	Symbol	Conditions	Min	Typ	Max	Unit
PWM input low level voltage	V _{PWML}	-	0	-	0.2xV _{CC}	V
PWM input frequency	f _{PWM}	-	0.02	-	50	kHz
Quick start enable time	t _{QS}	-	-	66.5	90	ms
Hall input offset voltage	V _{HOF5}	-	-	-	±6	mV
Input hysteresis voltage	V _{HYS}	-	±5	±10	±15	mV
Over temperature shutdown threshold	OTS	-	-	165	-	°C
Over temperature shutdown hysteresis	-	-	-	30	-	°C

Table 4. Electrical Characteristics

Truth Table

Input			Output			Mode
IN-	IN+	PWM	OUT1	OUT2	FG	
L	H	H	H	L	L	Normal operation mode
H	L		L	H	OFF	
H	L	L	L	L	OFF	
L	H		L	L	L	
L	H	-	L	L	OFF	Lock protection mode
H	L		L	L	OFF	
-	-	L	OFF	OFF	OFF	Standby mode

Table 5. Truth Table

Power Dissipation Curve

Figure 2. Power Dissipation Curve

Typical Application
Type A: VCC speed control

Figure 3. Typical Application 1

Type B: VCC speed control with slope setting

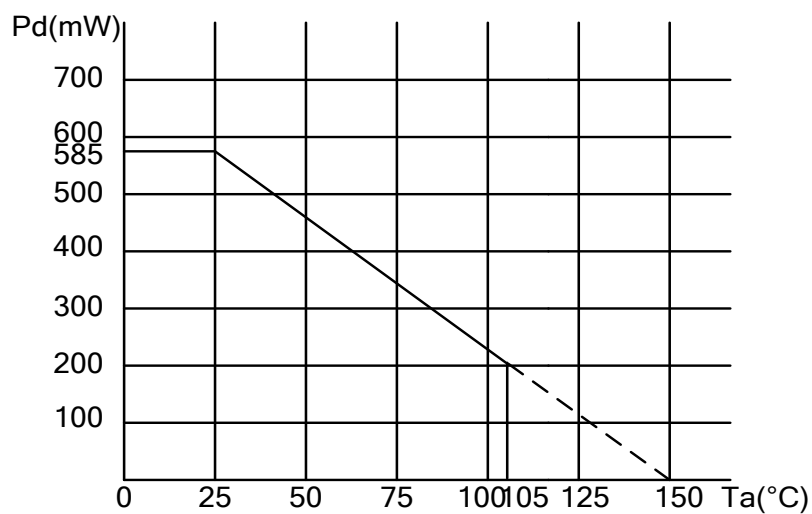
Figure 4. Typical Application 2

Type C: Direct PWM input speed control

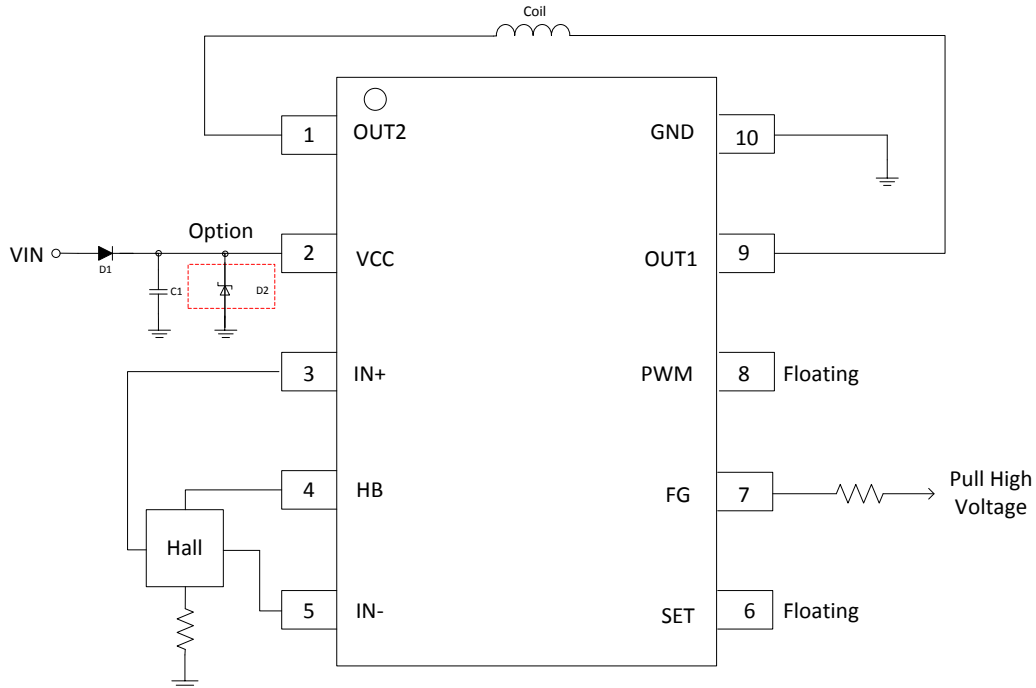
Figure 5. Typical Application 3

Note: for zener diode (D2) is optional choice.

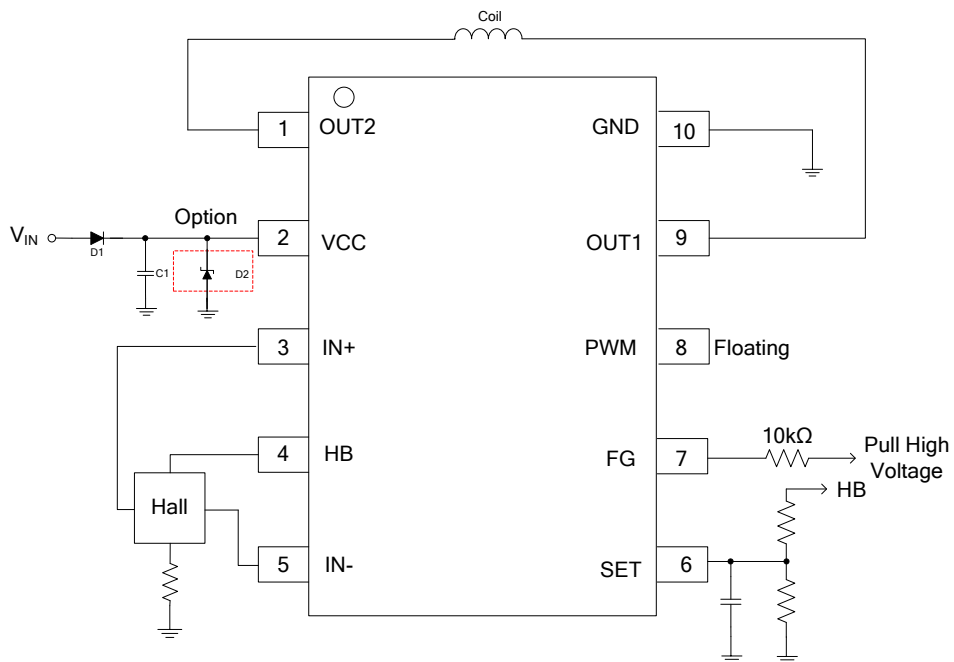
Function Description
Lockup Protection and Automatic Restart

The SDC11558 provides the lockup protection and automatic restart functions for preventing the coil burn-out in the fan is locked. This IC has an internal counter to determine the shutdown time (t_{OFF}) and restart time (t_{ON}). During shutdown time, the output

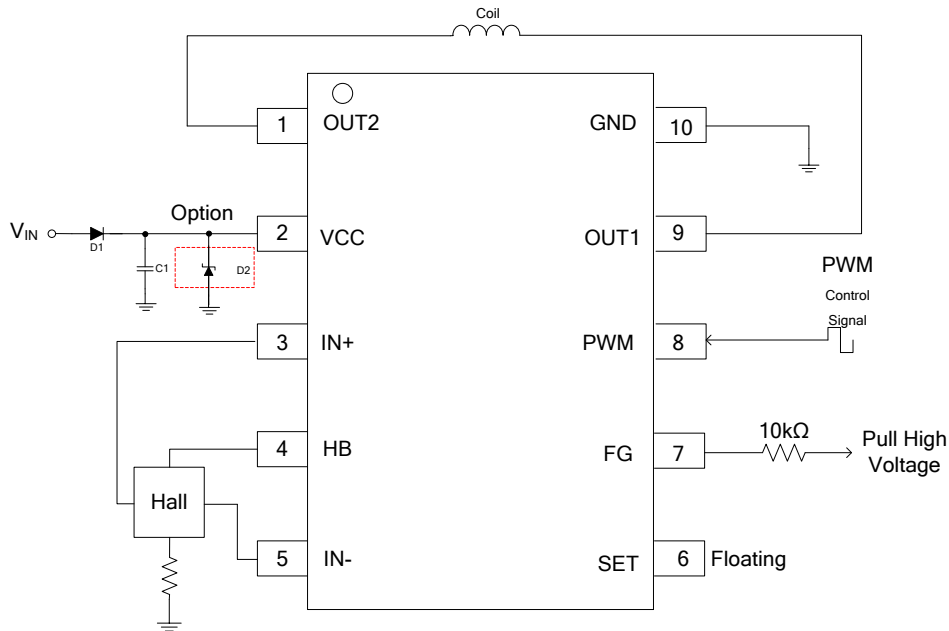
drivers keep turning off for 5 seconds and then enter the restart time. During the restart time, one output is high and the other is low, which makes a torque for fan rotation. The restart time has 0.5 second. If the locked condition is not removed, the shutdown restart process will be recurred until the locked condition is released (see Figure 6. Lockup/Auto Restart Waveform).

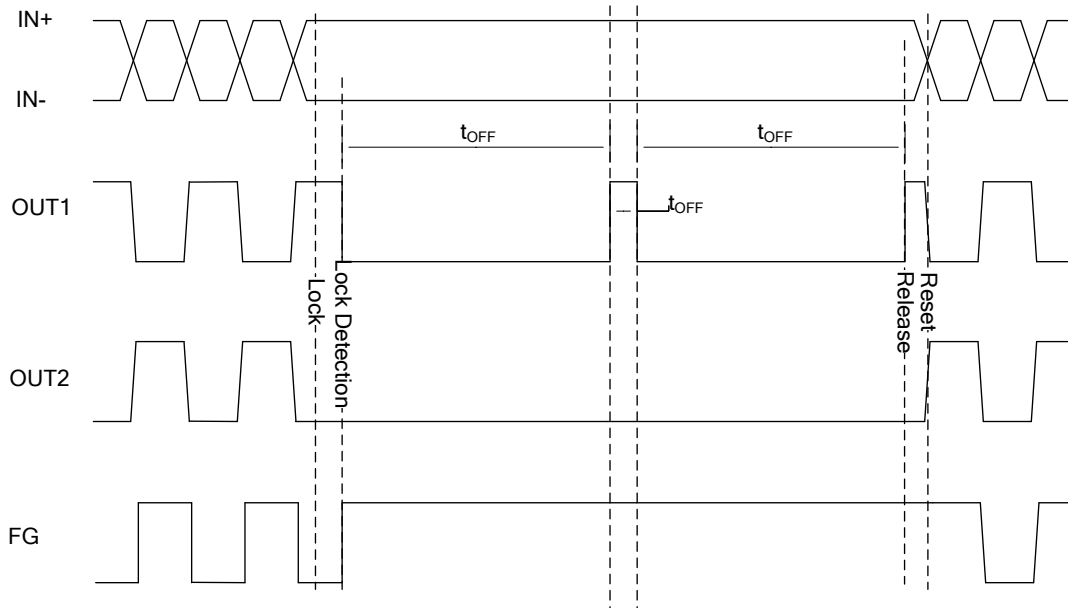

Figure 6. Lockup /Auto Restart Waveform

Speed Control Function

The SDC11558 builds in three speed control types, which

are VCC speed control (Type A), VCC speed control slope setting (Type B), and direct PWM input speed control (Type C).

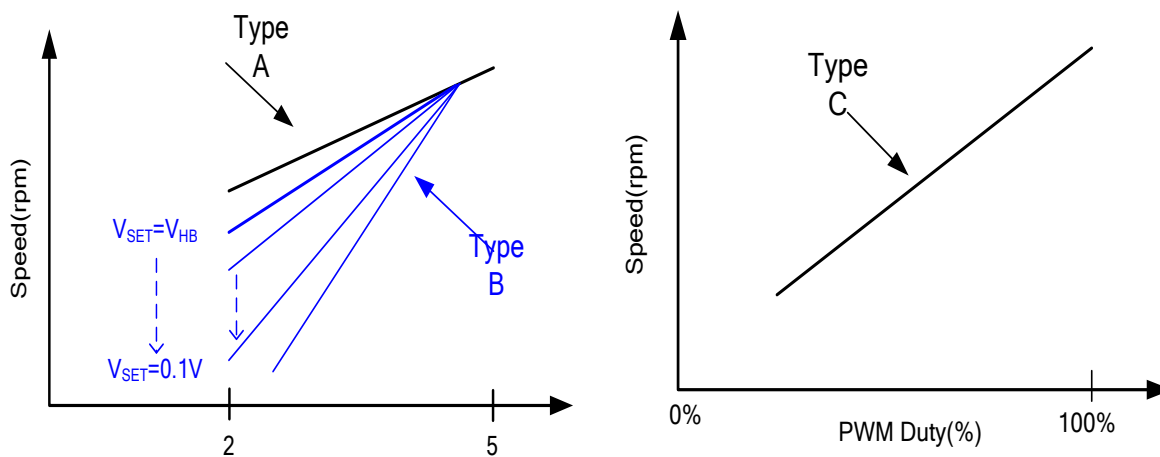

Figure 7. Speed Control Function

Quick Start and Standby Mode (Type C only)

This IC would enter standby mode when the PWM input keeps low level for more than 66.5ms (typ.). In standby mode, it will shutdown amplifier and FG. Thus, the

supply current is around 100mA. In standby mode, the lock protection function doesn't work, therefore, starting fan is unobstructed when releasing standby mode.

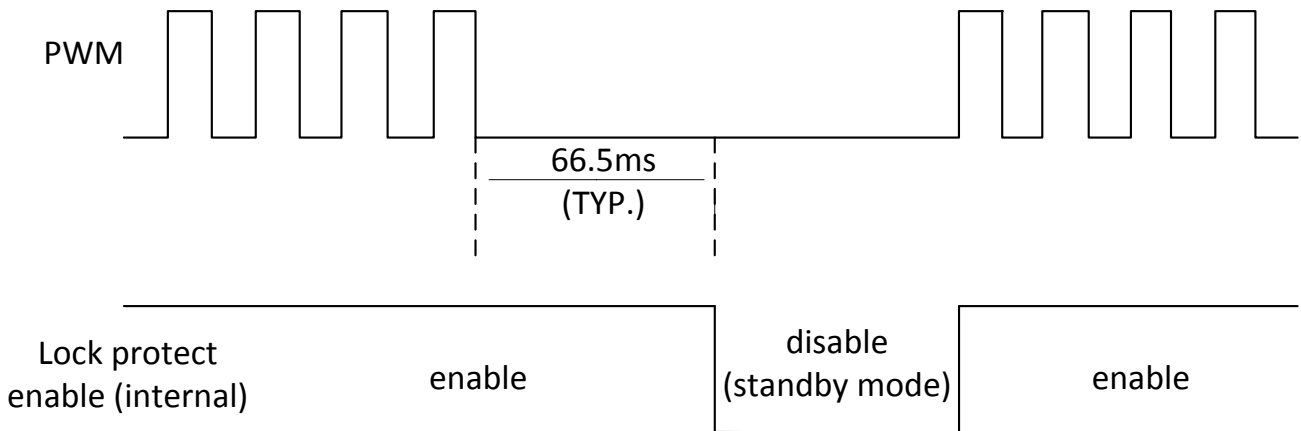

Figure 8. Quick Start Waveform

Output Drivers

All four drivers in the bridge output are designed for single phase full wave motor driver for fan motor. The linear output architecture is used as output driver.

Low Duty Start up Function

When motor start-up from stop condition, outputs are driven in not less than PWM 50% duty until detecting motor rotation(max 250 ms).Even if input duty of PWM is low, the motor can be started by this function. And if input duty of PWM is high, this function can limited the output current at starting moment, avoiding the impact of the power. When the IC is in lock protection mode, this function can also reduce the temperature rise.

If V_{CC} is greater than 4V, outputs are driven in PWM 50%

and 25 kHz Frequency when motor start-up or restart from lock protection mode.

If V_{CC} is less than 4V, this function guarantees outputs keep continuous conduction 20 us at every rising edge of PWM signal, after whether conduction is determined by PWM signal: If FPWM is not less than 25 kHz and input duty of PWM is lower than 50%, the function will guarantee the starting duty greater than or equal to 50%;if input duty of PWM is higher than the guaranteed duty, then the starting duty will be equal to PWM signal duty; If FPWM is 50 kHz, the starting duty will be 100%; The opposite, if FPWM is less than 25 kHz and input duty of PWM is lower than 50%, the starting duty will be lower than 50%.

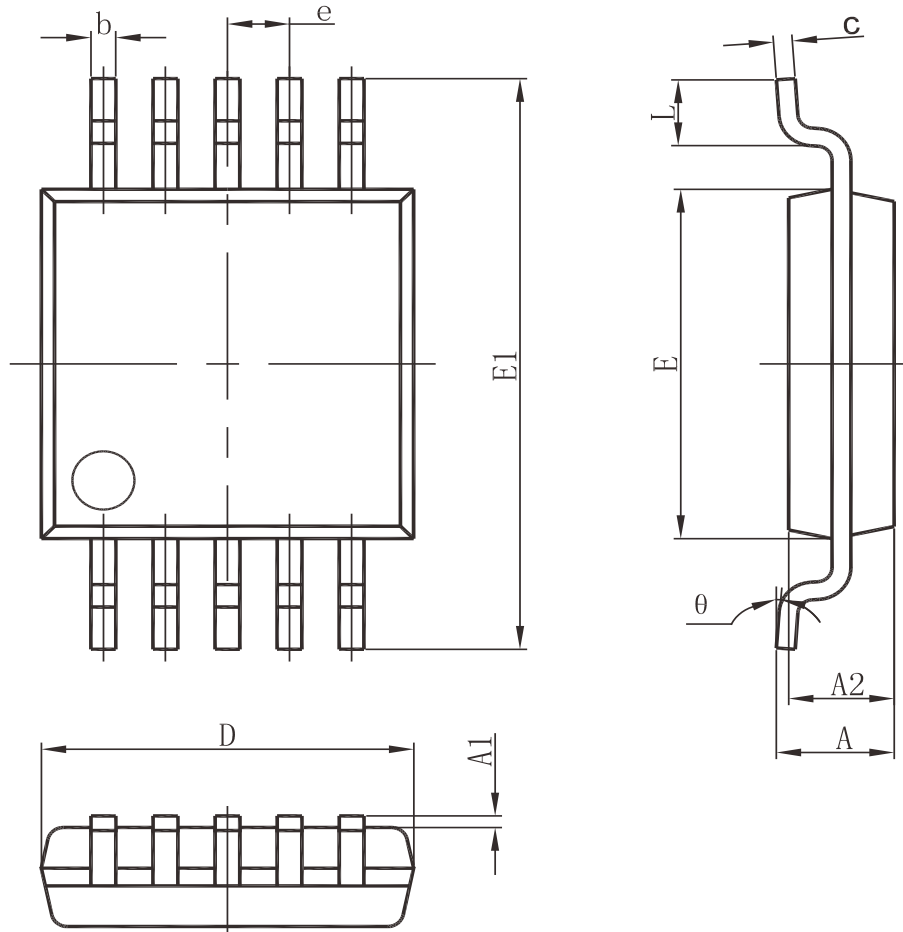
Package Dimension
MSOP-10

Symbol	Dimensions In Millimeters		Dimensions In Inches	
	Min	Max	Min	Max
A	0.820	1.100	0.032	0.043
A1	0.020	0.150	0.001	0.006
A2	0.750	0.950	0.030	0.037
b	0.180	0.280	0.007	0.011
c	0.090	0.230	0.004	0.009
D	2.900	3.100	0.114	0.122
e	0.50(BSC)		0.020(BSC)	
E1	4.750	5.050	0.187	0.199
E	2.900	3.100	0.114	0.122
L	0.400	0.800	0.016	0.031
θ	0°	6°	0°	6°



Shaoxing Devechip Microelectronics Co., Ltd.

<http://www.sdc-semi.com/>

IMPORTANT NOTICE

Information in this document is provided solely in connection with Shaoxing Devechip Microelectronics Co., Ltd. (abbr. SDC) products. SDC reserves the right to make changes, corrections, modifications or improvements, to this document, and the products and services described herein at anytime, without notice. SDC does not assume any responsibility for use of any its products for any particular purpose, nor does SDC assume any liability arising out of the application or use of any its products or circuits. SDC does not convey any license under its patent rights or other rights nor the rights of others.

© 2013 Devechip Microelectronics - All rights reserved

Contact us:

Headquarters of Shaoxing

Address: Tian Mu Road, No13,

Shaoxing city, Zhejiang province, China

Zip code: 312000

Tel: (86) 0575-8861 6750

Fax: (86) 0575-8862 2882

Shenzhen Branch

Address: 22A, Shangbu building, Nan Yuan Road, No.68,

Futian District, Shenzhen city, Guangdong province, China

Zip code: 518031

Tel: (86) 0755-8366 1155

Fax: (86) 0755-8301 8528